

EXELTRONIC XXL

Safety timing module for interlocking control

- Activation by a dual channel pushbutton with 2 contacts NC
- Short-circuit monitoring of input
- Compatible with safety switches fitted with Acotom process
- Instantaneous 3 NO contacts for engine control or heating resistances of single- or Three-phase motors
- 2NO+1NC delayed contacts
- Adjustable timing setting (from 0 to 999s)
- Power supply : 24Vac/dc



Safety category

EXELTRONIC XXL(V) : category 4 PLe according to ISO13849-1

Dimensions

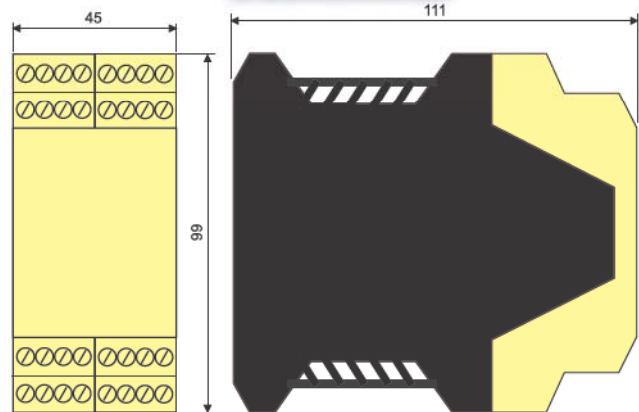

Wiring example

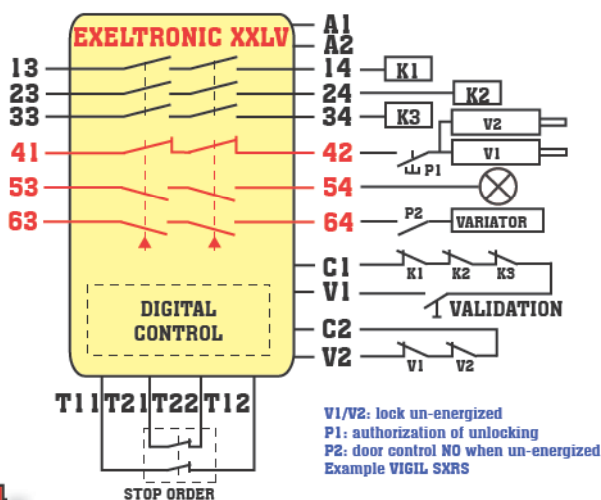
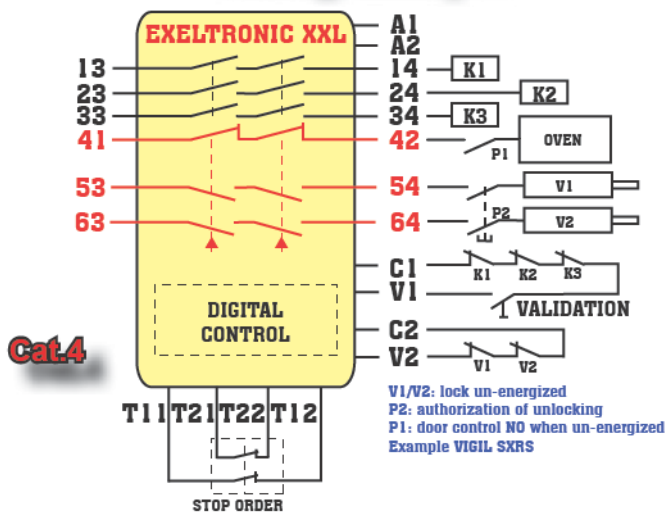

This unit incorporates a self-monitoring system of category 4, a digital timing circuit and a reset system. EXELTRONIC XXL controls all the safety gates of a machine. Connected to Anatom safety switch and an interlocking device, it provides an economical safety solution.

Application

The unit is to stop the machine and maintain the deceleration of an engine by means of a frequency variator. Then after a determined time, you can unlock the door securely.

