

EC DECLARATION OF CONFORMITY

This document is the conformity declaration concerning safety switches and relays, conform to the Machine Directive 2006/42/CE and the Directive 2004/108/CE.

SAFETY SWITCHES

We hereby certify that the hereafter described safety components both in its basic design and construction conforms to the applicable European Directives.

Name of products :

Range	Safety Standards	Conformity
MASSIMOTTO X5 AR	ISO 13849-1 EN 62061	CE
MASSIMOTTO X5 SR	ISO 13849-1 EN 62061	CE
MASSIMOTTO X5.2 AR	ISO 13849-1 EN 62061	CE
MASSIMOTTO X5.2 SR	ISO 13849-1 EN 62061	CE

PL=d acc. EN ISO 13849-1
 SIL 2 acc. EN 62061
 Classification=PDF-S
 acc. EN 60947-5-3
 Input Power Supply = 24VDC
 Checking period=1/year
 PFH=1,42 E-08
 PFD=1,24 E-03
 PROOF TEST=20 a
 dop=365 j
 hop=24 h
 F=1/h
 B10d=2.000.000
 Supply : 24 VDC PELV/SELV
 Coding level : low acc. ISO 14119
 Average level on demand

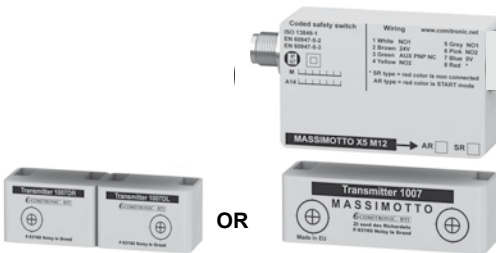

Description :

Coded safety switch with process Acotom[®] for detects the position of the doors. It can used without safety relay.

Person authorized for the compilation of the technical documentation :

Christophe PAYS
 34 Allée du Closeau
 93160 Noisy le Grand



U.S. market : All products are manufactured with UL components and 94VO housing

Place and date of issue : Noisy, december 18, 2014

Authorised signature
 Michel Conte
 President

Technical data sheet of MASSIMOTTO X5 M12 AR

Thank you for your confidence in BTI products. This product has been designed and manufactured according to the highest quality standards.

1. Application

MASSIMOTTO X5 M12 AR is a coded magnetic switch that detects the opening of doors and crankcases of dangerous machines. It uses our ACOTOM₃® process, « interactive self-controlled » system, which locks the safety lines in case of failure. The safety is ensured without any external device. It is composed of one receiver and one transmitter in polycarbonate. It provides two NO contact lines free of potential, independent and isolated from the decoding system for a perfect safety, and a static NC contact compatible with PLC, indicating the exact state of the switch. A special transmitter (1007D) allows to use the single sensor on a door with double hinge door.

2. Fixing and wiring

The transmitter and receiver are easily fixed with 4mm diam. screws (length 20mm). It is compatible with all aluminium profiles present in the market. The anti-tamper screws and tool are optional. The receiver is equipped with a male 8 points IP67 M12 connector and a screw over.

3. Functioning

The receiver is supplied in 24Vac or 24Vdc. Targets are printed on the sensitive faces. When they face each other, if the code is recognised, the NO lines close and the auxiliary line opens. The yellow LED lights up. If the code is not recognised, if there is a too big misalignment or if the switch detects a failure of one of its safety contacts, the LED is lit off and the lines are not ordered. The MASSIMOTTO X5 M12 AR has an input for a reset by a NO external contact. In order to avoid violent chocks, to leave a distance of at least 1mm between the transmitter and the receiver is advised. This product should not be used to block the machine doors mechanically. The detection distance between both elements is 8mm. The detection can also be done through a 6mm wide wall in polycarbonate or stainless steel.

4. Electrical diagram

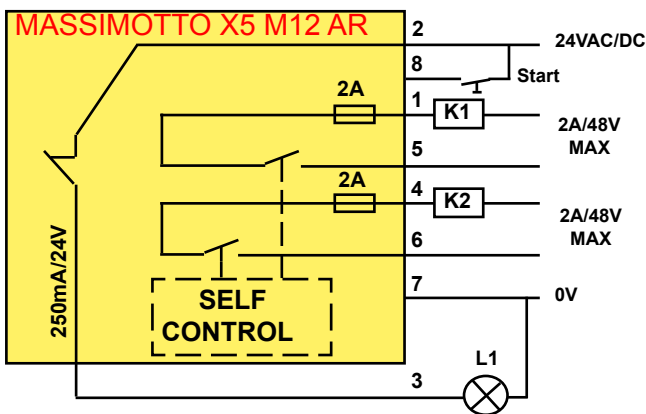

Remark :
The installation of the safety has to be checked periodically. Our engineers team stays at your disposal to answer your questions and analyse all your specific demands (research, specific manufacture...). Please do not hesitate to contact us.

5. Technical characteristics

Supply	24Vac/dc - 15% / +10% 50/60Hz	
Current	57mA (dc) / 88mA (ac)	
Safety line protection	Fuse each line : 2A/48V cos Φ=1	
Auxiliary output	Sortie NF PNP (power supply) / 250mA	
Detection / Hysteresis	8 mm / 3 mm / lateral +/- 7 mm	
Response Time	10 ms	
Temperature	-25 °C / +60 °C	
Protection Class	IP 67	
Size L x l x h	Emitteur 25 x 77 x 25 mm	Receiver 48 x 77 x 25 mm
Weight	Emitteur 66 g	Receiver 148 g

6. Wiring

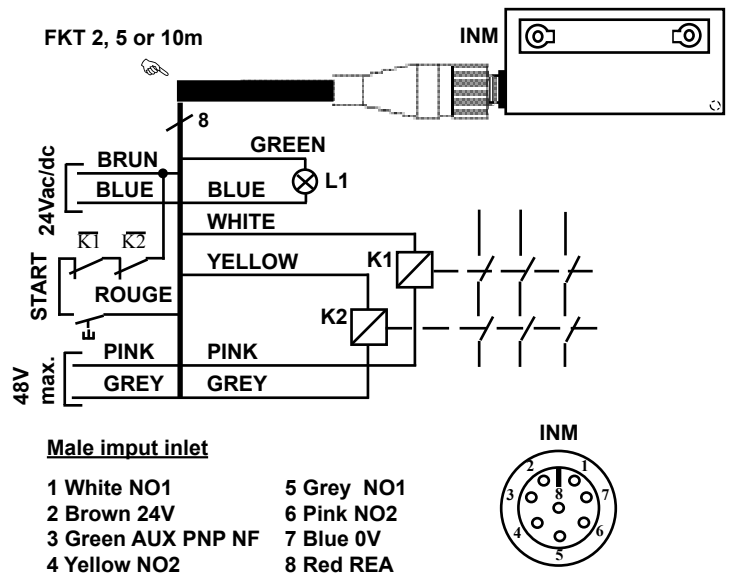

7. Dimensions (mm)

Transmitter 1007D
Double hinge door version

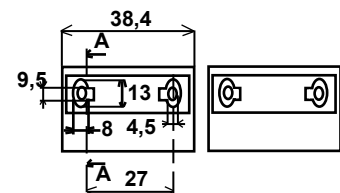

Transmitter 1007
Simple door version

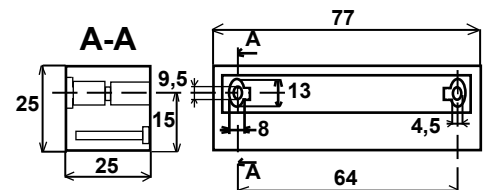

Receiver

