

# VALTRONIC

## Protection of operators in death zones

- Protection of an operator placed in a death zone
- 2 independent lines of command to activate up to 2 safety systems & 1 NC auxiliary line
- Pushing on 2 buttons of which 1 is priority
- Delaying time adjustable by font wheel setting
- Delaying time: 0, 2, 4, 6, 8, 12, 16, 18, 20, 22s
- Power supply : 24V



### Safety category

VALTRONIC : Category 4 PLe according to ISO13849-1. The safety category depends of the system to reset.

### Wiring diagram

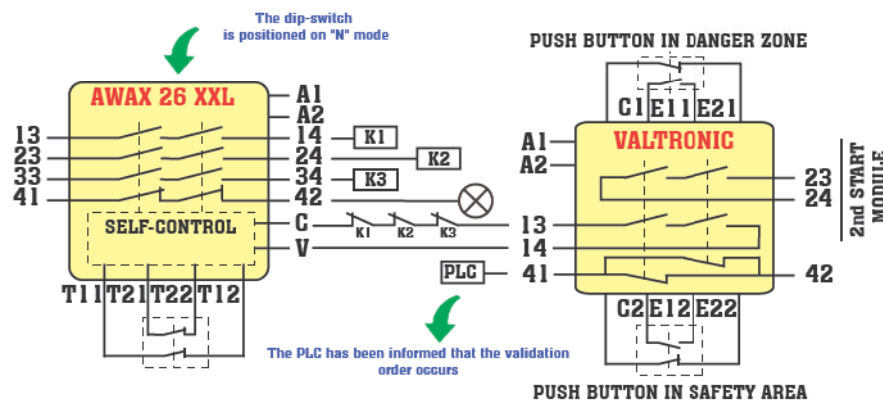

### Dimensions

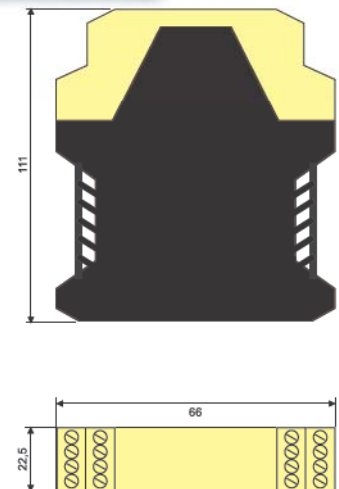

**Cat.4**

### Application

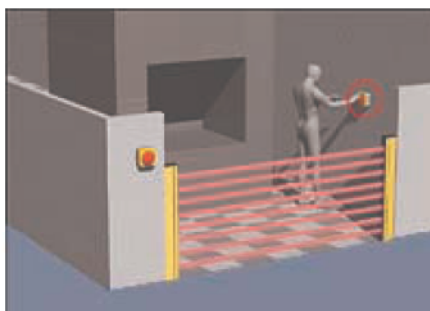

**Press the A button first  
the worker is in safety**

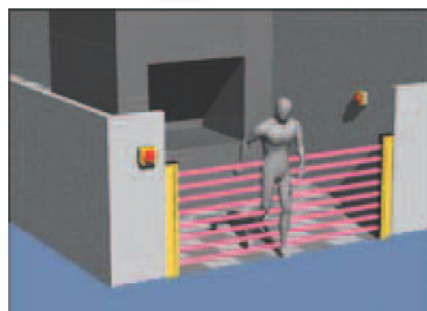

**The worker gets out from the zone and presses the B button. He must do it in scheduled time to reset the machine.**

