

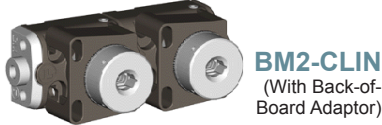

**BM1-CLIN**  
(With Bolt Extension)



**BMS1-CLSS**  
(Full Stainless Steel)



**BM2-CLIN**  
(With Back-of-Board Adaptor)

The **BM** is a robust, modular mechanical bolt interlock that is used to interface with power breakers, valves, earth switches etc, where hazards need to be indirectly interlocked (often with the use of levers and cams). This product is also available in full stainless steel (**BMS**). **BM** may be surface or panel mounted using the optional M-BOB Adaptor. **BMS** is only surface mounted. **BM** is available with a choice of CL or ML lock mechanisms. All CL / ML locks can be supplied with stainless steel spring-loaded dustcovers and/or colour coding as optional extras. **BMS** is available with a choice of CLS or MLS lock mechanisms. All CLS / MLS locks are supplied with stainless steel spring-loaded dustcovers as standard and colour coding as an optional extra.

**IMPORTANT: This product is designed for use according to the installation and operating instructions enclosed. It must be installed by competent and qualified personnel who have read and understood the whole of this document prior to commencing installation. Any modification to, or deviation from these instructions invalidates all warranties. Fortress Interlocks Ltd accepts no liability whatsoever for any situation arising from misuse or mis-application of this product.**

**IF YOU HAVE ANY QUESTIONS OR QUERIES OF ANY NATURE WHATSOEVER PLEASE CONTACT THE SUPPLIER WHO WILL BE PLEASED TO ADVISE AND ASSIST.**

### Construction BM

**Body Housing:** Die-cast zinc with pearl bronze finish.

**Internals:** All stainless steel

**Bolt:** All stainless steel.

**Lock Mechanism:** CL or ML lock types are of die-cast zinc body with stainless steel operating mechanism.

**Key:** Stainless steel.

**M-BOB:** Die-cast zinc with pearl bronze finish.

### Construction BMS

**Body Housing:** Full stainless steel

**Internals:** Full stainless steel

**Bolt:** All stainless steel.

**Lock Mechanism:** CLS or MLS lock types are of all stainless steel.

**Key:** Stainless steel.

**Spring Loaded Dustcover:** Stainless steel.

### Tools and Fixings Required

2 off Cap head / hexagonal head bolts for each module.

Front of Board mounting:

M6 x 25 or 1/4" x 1"

Back of Board mounting:

M6 x 55 or 1/4" x 2 1/4"

Suitable driver for above.

If using through holes:

- 1 off Drill Ø6.5 (or Ø5/16").
- 2 off M6 (or 1/4") Full nuts per module.

If using threaded holes:

- 1 off Drill Ø5 (or Pilot Drill for chosen 1/4" Thread).
- 1 off M6 (or 1/4") Tap and wrench.

End Fixings for mounting

M6 x 20mm longer than the panel thickness (Maximum length).

### Mounting

Mount this unit well away from sources of vibration or use anti-vibration mountings in order to avoid the effects of vibration, shock and bump.

Mount the unit only in its correctly assembled condition to flat steel plate of minimum thickness 3.0mm or 6.0mm if aluminium. **BM/BMS** can be mounted in any orientation, observing the following rules:

- 1 Locate the unit so that all the locks are within easy reach.
- 2 The bolt may be used to interface with mechanical linkages e.g. levers or cams on proprietary switchgear applications. Mounting kits must be either fabricated to suit or some are available from switchgear manufacturers. The bolt travels a distance of 16mm when free. When sequencing is used to prevent movement of the bolt, tolerances in the lock allow up to 6mm of bolt movement (see Fig.1). Ensure this tolerance movement does not allow any proprietary application to change state.
- 3 Mount the unit to the panel using the chosen fixings.
- 4 Tighten the fixings to a Torque of 8 to 10 N m (5.9 to 7.4 lbf.ft)
- 5 All fixing screws must be permanently prevented from removal, either by vibration or by personnel using standard tools.
- 6 If a bolt extension is used, it should be supported at approx 25mm from the end to keep it straight.

**All fixings must be used.**

Fig.1.

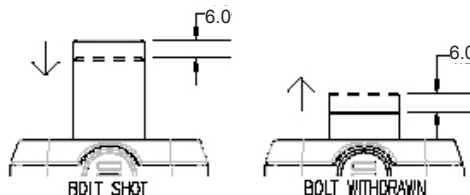

A 3mm gap between the front face of a BM/BMS and any galvanised metal work is recommended to reduce the likelihood of a galvanic reaction occurring.

**BM1/BMS1 (Single Module)** - With the key free the bolt is usually in the shot (extended) position. To withdraw (retract) the bolt the key must be inserted and trapped (reverse sequence is available upon request).

**BM2-10 / BMS2-5 (Multiple Modules)** - With the primary key free the bolt is usually in the shot (extended) position. To withdraw (retract) the bolt the primary key must be inserted, turned and trapped in the primary lock, and the secondary key turned and removed from the secondary lock (other sequences available on request).

### Sequencing

The **BM/BMS** system is extremely flexible in terms of its sequencing possibilities. Two types of operation are possible. These are used individually or mixed to provide complex operation. The two types of operation are:

#### Sequential Operation

This is when the key in the module interacts only with its neighboring modules. This dictates the order in which keys are inserted and removed.

#### Non-Sequential Operation

This is when two or more keys work together in a group. In a non-sequential system, any of the keys in the group can be operated together. Therefore, the order in which keys are inserted or removed from the group is not dictated. However, all of the keys in the group must be either all inserted and trapped or all removed.

The **BM/BMS** sequence should have been specified at the purchasing stage. If the sequence needs to be changed, contact Fortress Interlocks.

#### Fitting of Additional Key Exchange Modules

The **XMA/XMSA** is supplied with its own Installation Instructions.

#### Conversion from BM to XM or BMS to XMS

It is possible to convert a BM to an XM or a BMS to an XMS. However, this must be done with care as the sequence may require modification. If the BM/BMS needs to be changed to an XM/XMS, contact Fortress Interlocks.

#### Conversion from BM to DM or BMS to DMS

It is possible to convert a BM to a DM or a BMS to a DMS. However, this must be done with care as the sequence may require modification. If the BM/BMS needs to be changed to a DM/DMS, contact Fortress Interlocks.

### Commissioning

#### Mechanical Function Test - Typical example Sequence

- 1 Start with the primary key inserted and the secondary key(s) removed.
- 2 Insert the secondary keys.
- 3 Remove the primary key and check that the bolt moves to the shot or withdrawn position depending upon product ordered.
- 4 Check that all of the secondary key(s) are trapped.

#### Service and Inspection

Regular weekly inspection of the following is necessary to ensure trouble-free, lasting operation:

- 1 Secure mounting of components.
- 2 Debris and wear.
- 3 If lubrication/cleaning is required all locks should be lubricated with WD40. **Do not use dry lubricant.** The frequency of lubrication/cleaning will depend on the environment. Lubricate/clean at least once a week when used in the concrete industry.

There are no user serviceable parts in a BM/BMS module. If damage or wear is found, the whole module must be replaced.

#### Disposal

The BM/BMS does not contain any certified hazardous materials so should be disposed of as industrial waste.

#### Liability coverage is voided under the following conditions:

- 1 If these instructions are not followed.
- 2 Non-compliance with safety regulations.
- 3 Installation not performed by authorised personnel.
- 4 Non-implementation of functional checks.

# BM Drawing

# Installation Instructions

Product	Dimension A Overall length	Dimension B N° of slotted holes	Dimension C N° of CL locks
BM(S)1	60.15	2	1
BM(S)2	117.30	4	2
BM(S)3	174.45	6	3
BM(S)4	231.60	8	4
BM(S)5	288.75	10	5
BM6	345.90	12	6
BM7	403.05	14	7
BM8	460.20	16	8
BM9	517.35	18	9
BM10	574.50	20	

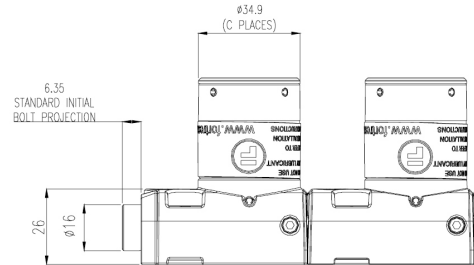
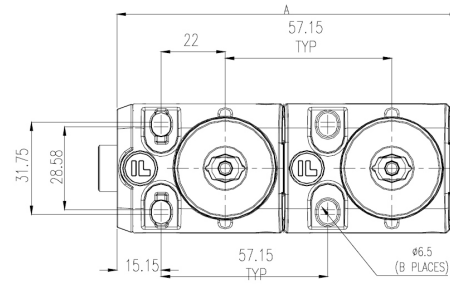
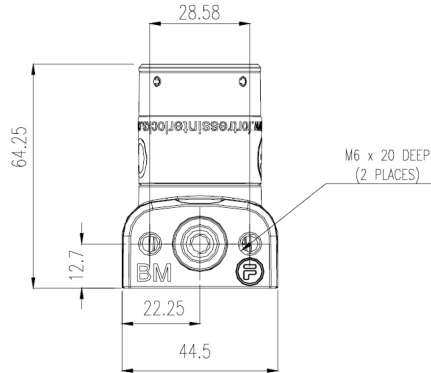

# BMS Drawing

Product	Dimension A Overall length	Dimension B N° of slotted holes	Dimension C N° of CL locks
BM(S)1	60.15	2	1
BM(S)2	117.30	4	2
BM(S)3	174.45	6	3
BM(S)4	231.60	8	4
BM(S)5	288.75	10	5

ALL DIMENSIONS ARE NOMINAL AND ARE SUBJECT TO MANUFACTURING TOLERANCES

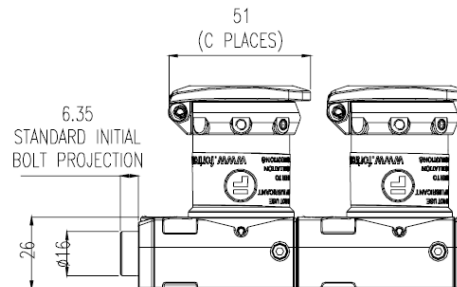
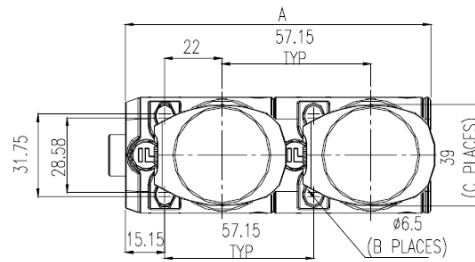
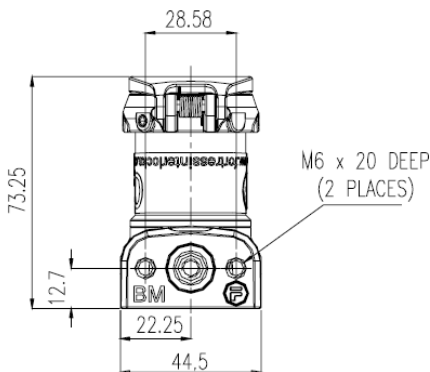

BOLT TRAVEL IS 16mm.